



Design and applications

The DDM-DS11 measuring system measures and monitors the flow rate of liquids and gases.

The device works according to the principle of differential pressure. The differential pressure at the orifice is proportional to the square of the volume rate of flow through the pipeline. The user mounts the orifice between flanges or with Rp pipe unions into the conduit. The unimpeded, straight tube length has to be 6 DN before and 4 DN behind the mounting position.

The DS11 gauge contains a rugged and uncomplicated diaphragm system. The differential pressure generates a unilateral force at the membrane which moves the diaphragm system against the measuring range springs. A centre-mounted tappet transfers motion of the diaphragm system to indicator movement and to initiating elements of the microswitches. Due to the completely mechanical functionality, no external power supply is needed.

The applications of DDM-DS11 are engineering and process technology such as the monitoring of coolant streams in plants.

The display pressure gauge can be equipped with one or with two microswitches.

DDM-DS11



- with differential pressure gauge DS11
- installation between flanges as per DIN EN 1092-1, internal and external threads as per DIN EN ISO 228 or with pipe union as per DIN EN 10226-1 (ISO 7-1)
- one device for all installation situations and flow directions
- suitable for liquids and gases
- no moving parts, wear-free
- calibration acc. to customer specifications
- metering range 1:6
- accuracy 5 % FS
- optionally
 - up to two microswitches
 - wall attachment installation

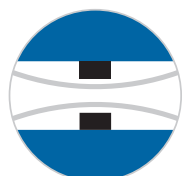

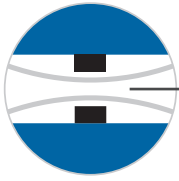

DDM-DS11

Differential pressure flow meters

Type series

DDM-DS11	Measuring orifice with indicator DS11
DDM-DS11 DN	Measuring orifice for in-between flange assembly
DDM-DS11 Rp	Measuring orifice for pipe union connection
DDM-DS11 Gi	Measuring orifice with internal thread
DDM-DS11 Ga	Measuring orifice with external thread
DDM-DS11-...-MS1	with one microswitches
DDM-DS11-...-MS2	with two microswitches

Technical data

Measuring principle	differential pressure measurement on the orifice
Perm. ambient temperature	-10 ... +70 °C
Perm. media temperature*	standard -10 ... +70 °C max. 130 °C (insulated line) optionally HT-Type above 130 °C
Display unit	mechanical differential pressure measuring unit
In-between flange (DN)	for PN 10/PN 16 flanges acc. to DIN EN 1092-1 shape A & B
Pipe union (Rp)	two-part pipe fitting: insert with cylindrical internal thread acc. to DIN EN 10226-1 (ISO 7-1)
External thread (Ga)	cyl. external thread acc. to DIN EN ISO 228
Internal thread (Gi)	cyl. internal thread acc. to DIN EN ISO 228

*media must not freeze

Differential pressures and pressure resistance

Differential pressure for liquids	250 mbar ¹⁾
Differential pressure for gases	200 mbar ¹⁾
Pressure loss for liquids	appr. 30 ... 60 % from the differential pressure ²⁾
Pressure loss for gases	appr. 30 ... 60 % from the differential pressure ²⁾
Pressure resistance	PN 16

¹⁾ others on request

²⁾ in case of enquiry it should be gathered from the quotation

Technical data of the gauge

Measuring principle	Differential pressure at the orifice
Perm. ambient temperature	-10 ... +70° C
Perm. medium temperature*	-10 ... +70° C
Protection class	IP54 acc. to DIN EN 60529
Measuring accuracy	± 2,5 % FS

*media must not freeze

Materials

DDM-DS11 DN	
Ring	S355, optionally 1.4571
Corrosion protection	Epoxy powder coating, traffic blue (RAL 5017) glossy
Corrosion class	C3
Orifice	1.4571
DDM-DS11 Rp, Gi, Ga	
Pipe union (Rp only)	malleable cast iron, zinc plated
Orifice and ring	brass
Gaskets	NBR
Connection between orifice and indicator	
Straight screw-in fitting 1/4"	nickel-plated brass or stainless steel
Screw fitting G 1/4" dia. Ø 8	nickel-plated brass or stainless steel
Cutting ring, union nuts	zinc plated steel or stainless steel
Steel sealing	zinc plated steel with NBR gasket
Indicator DS11	
Pressure chamber	aluminium GkAlSi12 (Cu) with HART-COAT surface protection
Measuring diaphragm	NBR
Dial cover	polycarbonate

other materials on request

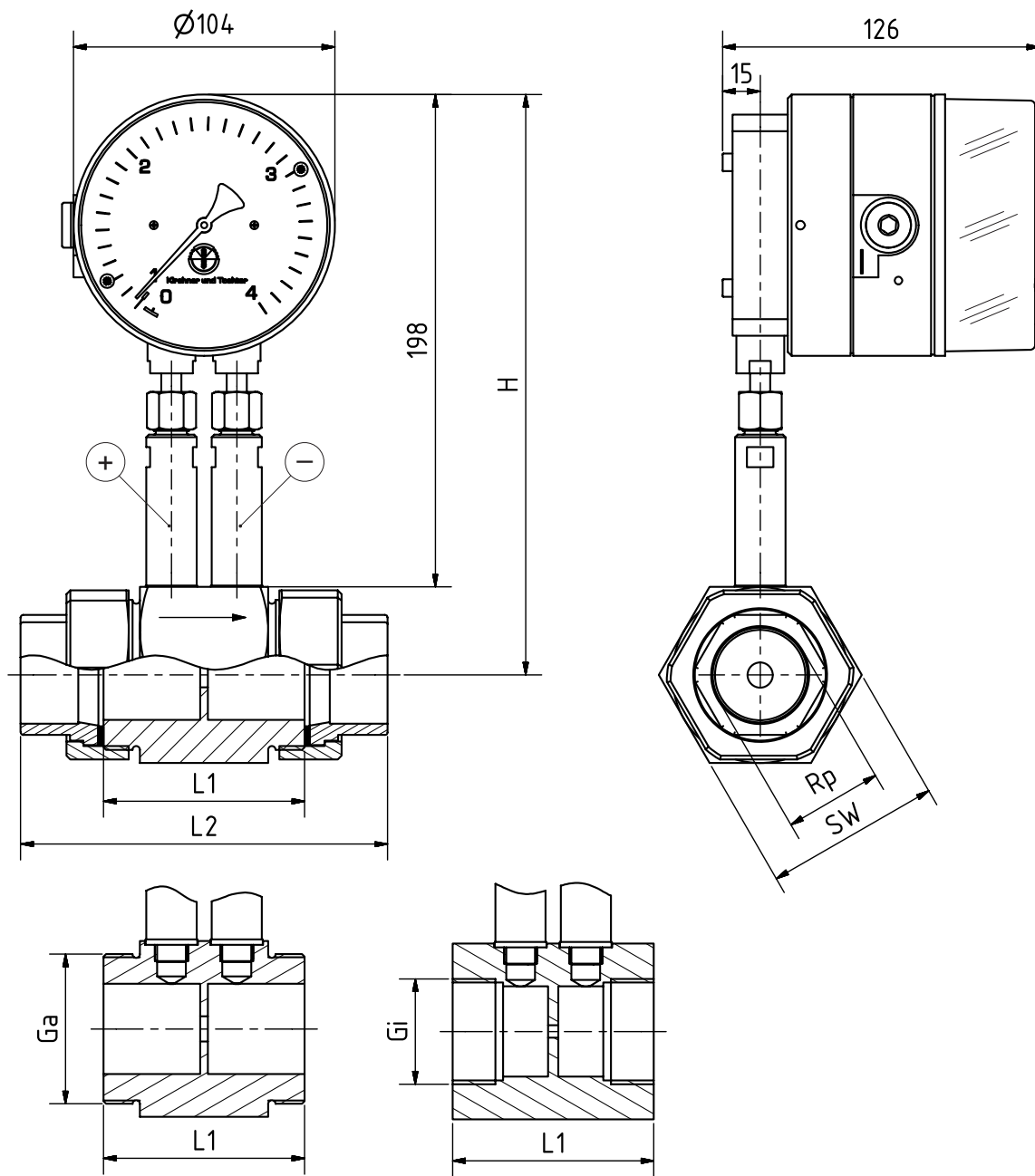

Dimensions for DDM-DS11 for screwed connections

Rp ¹⁾	L ₁	L ₂	SW	H
¼	80	124	41	218
⅜	80	128	46	221
½	80	128	46	221
¾	80	128	50	223
1	80	136	60	228
1¼	80	146	70	233
1½	80	149	70	233
2	90	164	85	240

¹⁾ inside diameter is made as specified by the pipe inner diameter

Dimensions for DDM-DS11 for external resp. internal thread

Gi ¹⁾	Ga ¹⁾	L ₁	SW	H
¼	⅝	80	41	218
⅜	¾	80	46	221
½	1⅝	80	46	221
¾	1¼	80	50	223
1	1½	80	60	228
1¼	2	80	70	233
1½	2¼	80	70	233
2	2¾	90	85	240

¹⁾ inside diameter is made as specified by the pipe inner diameter

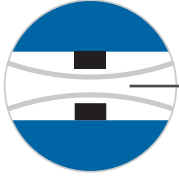

DDM-DS11

Differential pressure flow meters

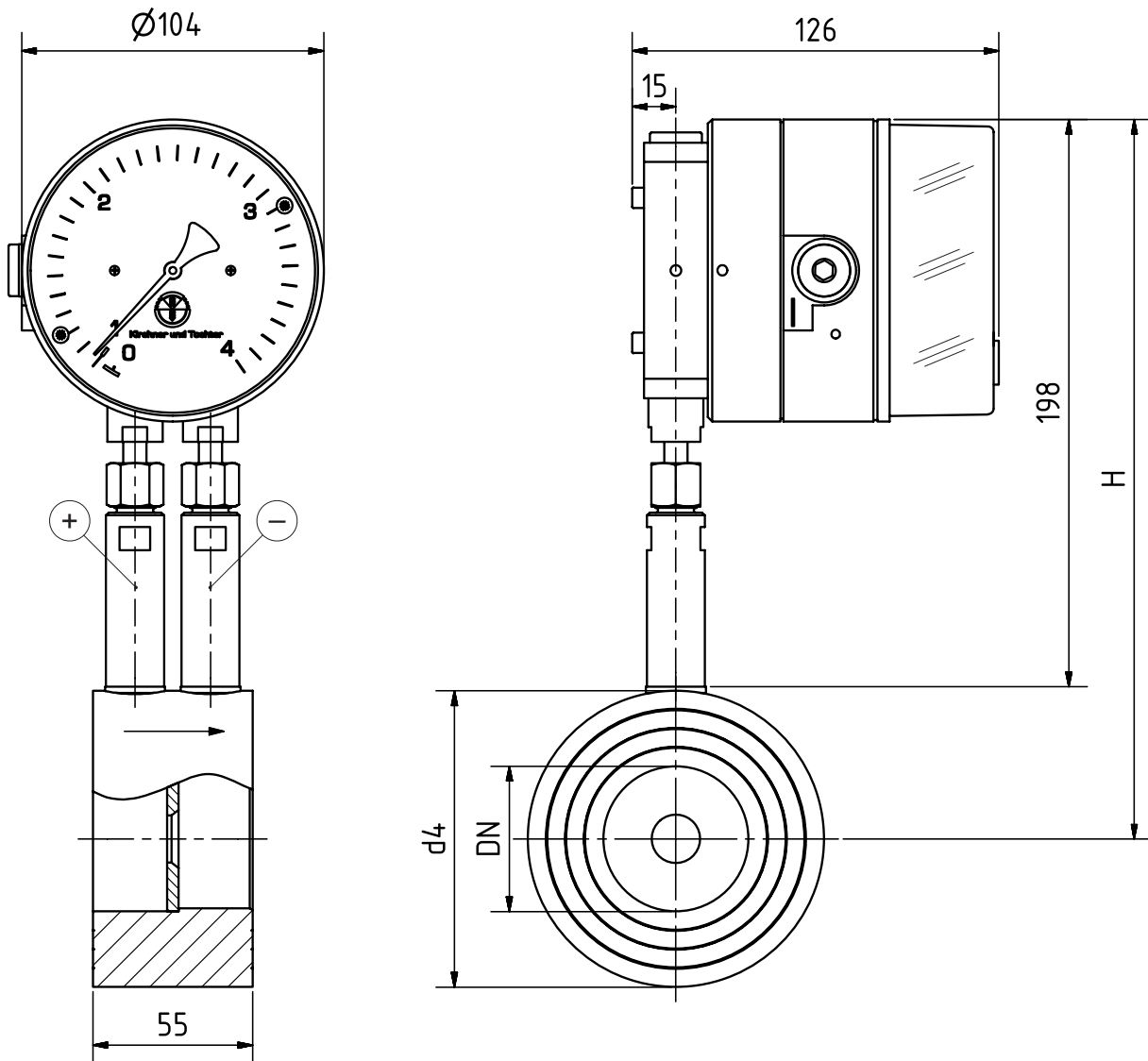

Dimensions for DDM-DS11 for in-between flange assembly

DN ¹⁾	d ₄	H
40	88	246
50	102	249
65	122	259
80	138	267
100	158	277
125	188	292
150	212	304
200	268	332

¹⁾ Inside diameter made after details provided of inside pipe diameter.

Installation variant mounted between flanges

The devices are delivered in ready assembled condition to customer specifications. All displayed situations could be installed by the customer with the delivered device. For backfitting you will need appr. 20 min and requires no additional materials.

The DDM-DS11 with bottom-mounted display may only be operated with a clean and particle-free medium. Rust particles or the like can accumulate in the display mechanism and may damage it.

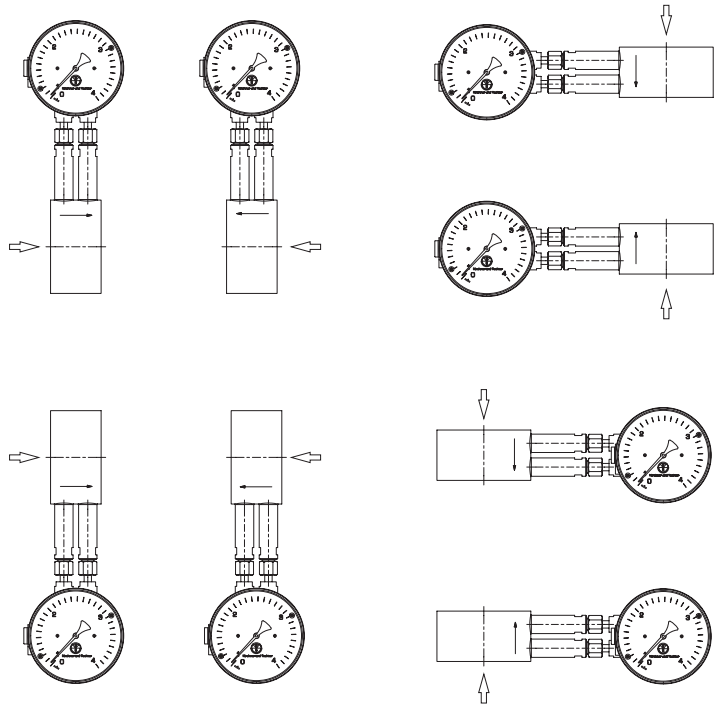

Installation variant with screw connections

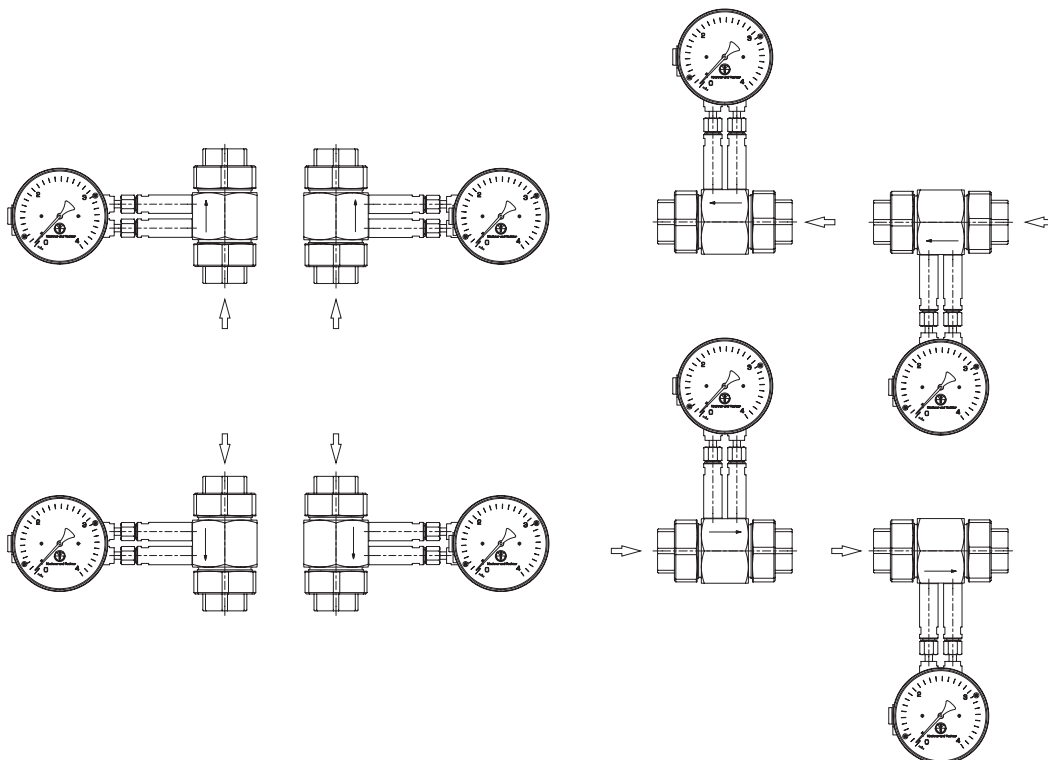

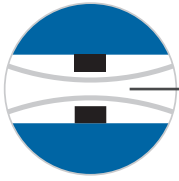

DDM-DS11

Differential pressure flow meters

Flow rates for water

for screwed connection fittings

Rp Gi	Ga	smallest measuring range [m ³ /h] H ₂ O			largest measuring range [m ³ /h] H ₂ O		
¼	⅝	0,05	-	0,3	0,2	-	1,2
⅜	¾	0,05	-	0,4	0,4	-	2,3
½	1 ⅛	0,1	-	0,7	0,75	-	4,5
¾	1 ¼	0,2	-	1,3	1,4	-	8,5
1	1 ½	0,35	-	2	2,25	-	13,5
1 ¼	2	0,6	-	3,5	4	-	24
1 ½	2 ¼	0,85	-	5	5,35	-	32
2	2 ¾	1,25	-	7,5	8,65	-	52

in-between ranges possible

for in-between flange assembly

DN	smallest measuring range [m ³ /h] H ₂ O			largest measuring range [m ³ /h] H ₂ O		
40	0,85	-	5	5,35	-	32
50	1,2	-	7	8,7	-	52
65	2	-	12	13	-	78
80	3	-	18	19,7	-	118
100	4,7	-	28	30,7	-	184
125	7,3	-	44	48	-	288
150	10,7	-	64	68,8	-	413
200	18,8	-	113	122,5	-	735

in-between ranges possible

Flow rates for air

for screwed connection fittings

Rp Gi	Ga	smallest measuring range [m ³ /h] air ¹⁾			largest measuring range [m ³ /h] air ¹⁾		
¼	⅝	0,5	-	3	1,3	-	8
⅜	¾	0,8	-	5	2,3	-	14
½	1 ⅛	1	-	6	3,5	-	21
¾	1 ¼	1,3	-	8	7,5	-	45
1	1 ½	2	-	12	9	-	54
1 ¼	2	4	-	24	18	-	108
1 ½	2 ¼	5,8	-	35	25	-	150
2	2 ¾	8,3	-	50	45	-	270

¹⁾ at STP (0° C and 1013 mbar)

in-between ranges possible

for in-between flange assembly

DN	smallest measuring range [m ³ /h] air ¹⁾			largest measuring range [m ³ /h] air ¹⁾		
40	5,8	-	35	25	-	150
50	9	-	54	45	-	270
65	13,5	-	81	83	-	500
80	20	-	120	125	-	750
100	35	-	210	142	-	850
125	60	-	360	292	-	1750
150	75	-	450	433	-	2600
200	125	-	750	667	-	4000

¹⁾ at STP (0° C and 1013 mbar)

in-between ranges possible

Technical data of microswitches

Switch output	1 or 2 microswitches, 1-channel change-over switch	
Adjustment of switching points	external adjustment by standard value scales	
smallest adjustable value	approx. 5 % of full scale range	
Switching hysteresis	approx. 2,5 %	
Load data/switches	AC U~ max. = 250 V AC, I max. = 5 A, P max. = 10 W	DC U~ max. = 30 V DC, I max. = 0,4 A, P max. = 10 W
Electrical connection	terminal box	

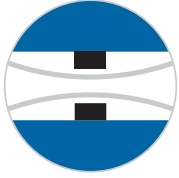

DDM-DS11

Differential pressure flow meters

Low Voltage Directive

The DS11 gauge meets the protection requirements of the Low Voltage Directive LVD 72/23/EEC and its modification 93/68/EEC.

Proper use

The user is responsible for assessing the suitability of the flow meters for his case of application, for use as prescribed, and for material compatibility regarding the fluid product used in his process.

The manufacturer shall not be liable for any damage arising from incorrect or improper use of the devices.

The equipment from **Kirchner und Tochter** has been tested in compliance with applicable CE-regulations of the European Community. The respective declaration of conformity is available on request. Subject to change without notice. The current valid version of our documents can be found at www.kt-flow.de

The **Kirchner und Tochter** QM-System is certified in accordance with DIN EN ISO 9001:2015. The quality is systematically adapted to the continuously increasing demands.